

LIFTMOORE 2550 CRANE

**25,000 FT.-LB. MOMENT RATING
5,000 LB. MAXIMUM CAPACITY**

Liftmoore's 2550 all hydraulic powered crane is the crane for your extended duty requirements. This model is designed for applications requiring longer duty cycles such as loading and unloading and longer lifting operations.

Moment rating of the 2550 is 25,000 Ft.-Lbs. Maximum lifting capacity is 5000 Lbs. at a 5 Ft. load radius. Plenty of capacity for most field service applications.

For precise control of the crane's rotation function a 45:1 ratio worm gear reducer drives a gear bearing slewing ring. 360 degree rotation without limit is standard on the 2550.

Three standard models are offered:

1. Model 2550 includes powered hoist, boom elevation and rotation functions with a manual boom extension from 10 Ft. to 16 Ft.
2. Model 2550X-16 includes all the above features but adds power to the 10 Ft. to 16 Ft. boom extension.
3. Model 2550X-20 adds 4 Ft. manual pull out extension to 20 Ft.

For other boom lengths or special needs contact Liftmoore or your local Liftmoore distributor.

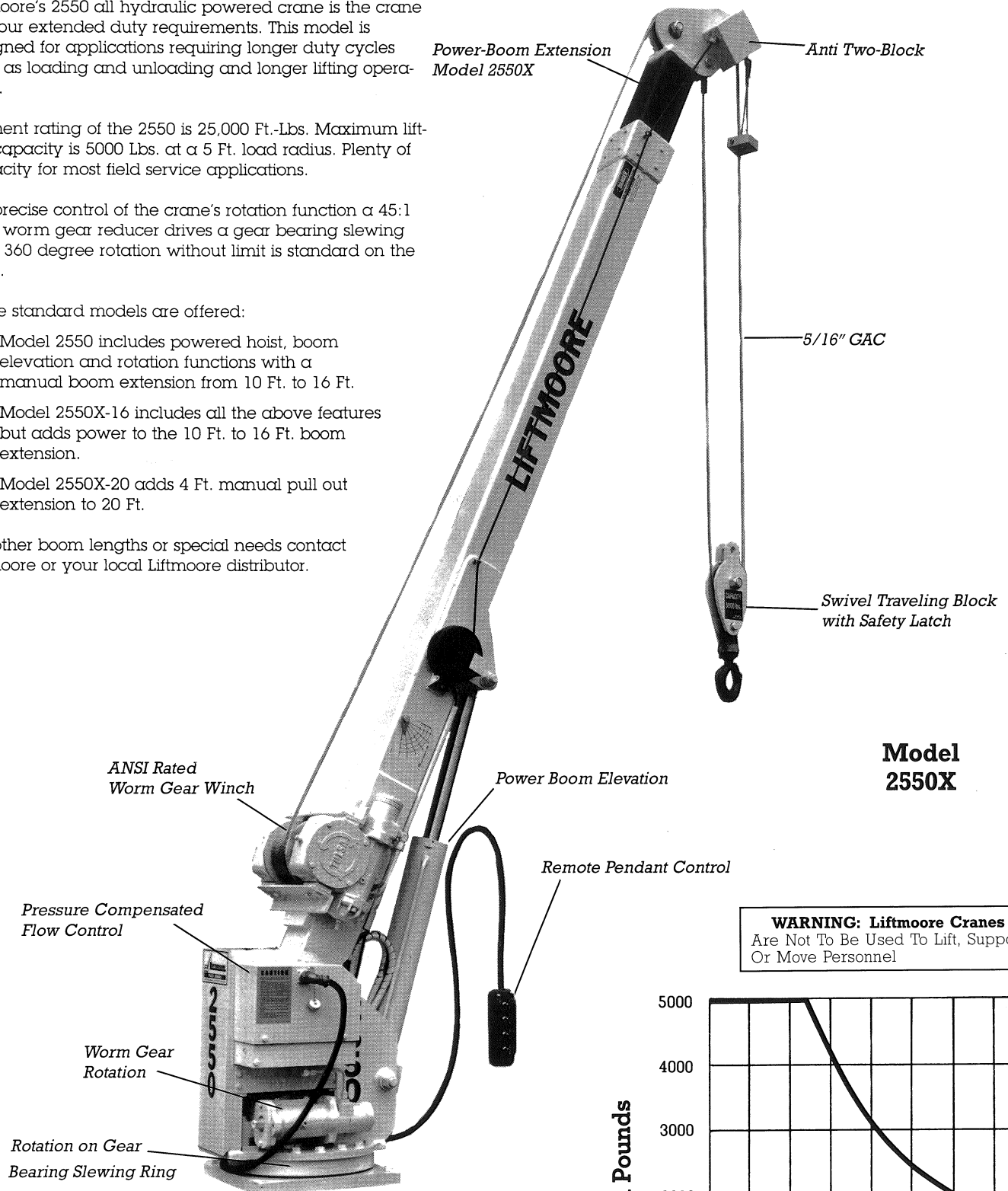

Model 2550X

WARNING: Liftmoore Cranes
Are Not To Be Used To Lift, Support
Or Move Personnel

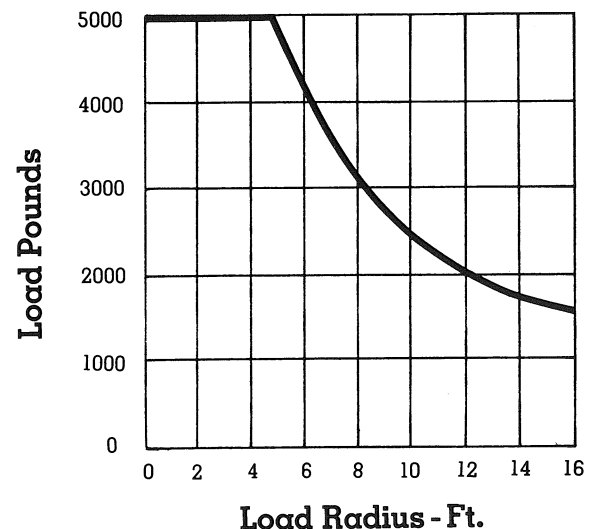

Up to 8000 lb. Capacity Cranes

LIFTMOORE, INC.
11505 Todd
Houston, Texas 77055
FAX (800) 824-5559 (USA & Canada)
FAX (713) 688-6324
(713) 688-5533
www.liftmoore.com

2550 SPECIFICATIONS

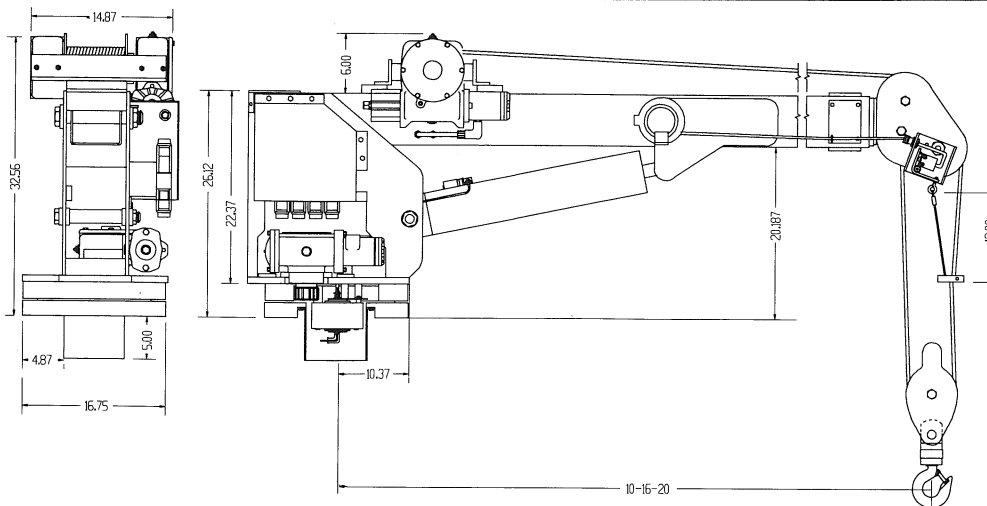

Moment Rating:

25,000 Ft.-Lbs.

Lift Capacities:

5000 Lbs. @ 5 Ft.	1562 Lbs. @ 16 Ft.
3125 Lbs. @ 8 Ft.	1388 Lbs. @ 18 Ft.
2500 Lbs. @ 10 Ft.	1250 Lbs. @ 20 Ft.
2083 Lbs. @ 12 Ft.	

Boom:

Standard length is 10 Ft. to 16 Ft. either manual or powered extension. An additional 4 Ft. manual extension to 20 Ft. is available. Manual booms have two intermediate stops. Powered extension booms include nylatron slide pads to reduce friction. An integrally mounted counterbalance valve is included with the cylinder for positive load holding. The boom angle varies from -5 to +75 degrees powered by a 4 in. diameter double acting hydraulic cylinder with counterbalance valve.

Winch:

The winch is a worm gear design with 38:1 gear ratio. A multiple disk safety brake is installed on the worm shaft. The winch is powered by a low speed, high torque hydraulic motor. Winch drum to wire rope ratio meets ANSI requirements. Single line no load speed of the winch is 20 Ft. per minute at 6 GPM flow.

Winch Cable and Block:

5/16" Galvanized Aircraft Cable 80 Ft. long is supplied with traveling block for double line operation. Breaking strength of the cable is 9800 Lbs. The swivel hook incorporates a roller thrust bearing for easier turning movement.

Rotation:

A worm gear speed reducer driven by a low speed, high torque hydraulic motor powers the crane's rotation function. The 2550 rotates on a gear bearing slewing ring. 360 degree continuous unlimited rotation is standard.

Hydraulic System:

For smooth operation and minimum heat buildup a pressure compensated flow control system is used. The system will not build up pressure above the level required to operate a function. This reduces the heat buildup in the oil and the power required from the engine. A parallel control circuit is used.

An optional **proportional control system** is available. This system provides variable speed control of each crane function with a constant input flow to the crane.

Manual override controls are provided for each hydraulic function.

Remote Pendant:

All powered functions are controlled by a remote pendant control that is 25 Ft. long. The pendant control is removable from the crane to prevent unauthorized use.

Electrical:

The 2550 crane's powered functions are all controlled by 12V DC electric solenoid valves. 25 Ft. of 10 gauge wire and a 15 Amp fuse are included.

Load Sensor:

A load sensor is standard on the 2550. The load sensor will not allow hoist up, boom down, or extension out when an overload condition is detected.

Anti Two-Block:

The 2550X includes an anti two-block feature that prevents extending the boom against the traveling block and breaking the wire rope.

Mounting:

Four 7/8" Grade 8 bolts are required. Bolts are not included. Crane mounts on a 16-3/4" square base plate with a 14-3/4" square bolt pattern.

Weights:

2550 - Actual: 1215 Lbs.	2550X - Actual: 1440 Lbs.
Shipping: 1365 Lbs.	Shipping: 1590 Lbs.

Optional Accessories:

- Jack Stand, over centering
- Outrigger - Manual pull out, crank down
- Outrigger - Manual out, hydraulic down/up
- Outrigger - Hydraulic in/out, hydraulic up/down
- Pedestal
- Boom Rest



LIFTMOORE, INC.
11505 Todd
Houston, Texas 77055
FAX (800) 824-5559 (USA & Canada)
FAX (713) 688-6324
(713) 688-5533
www.liftmoore.com