

HT 40-131-FLT

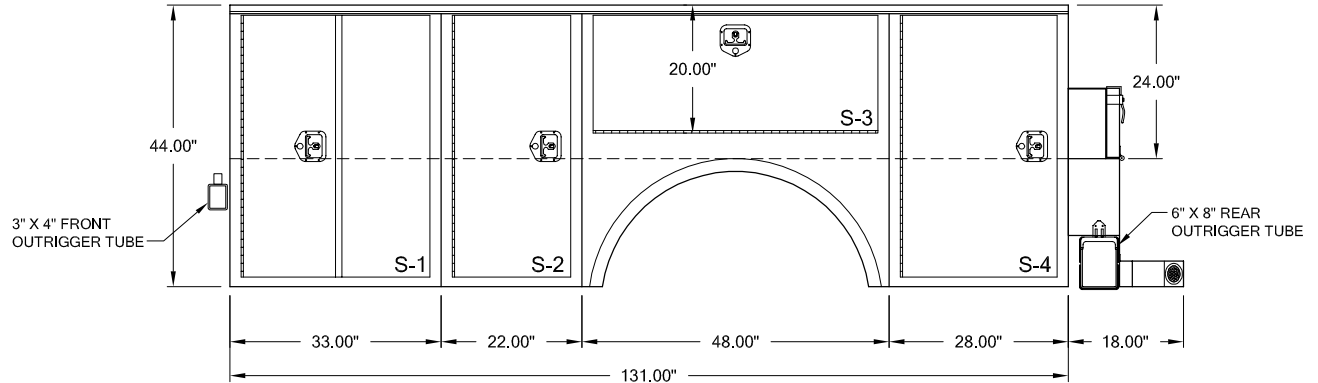

STREET SIDE VIEW

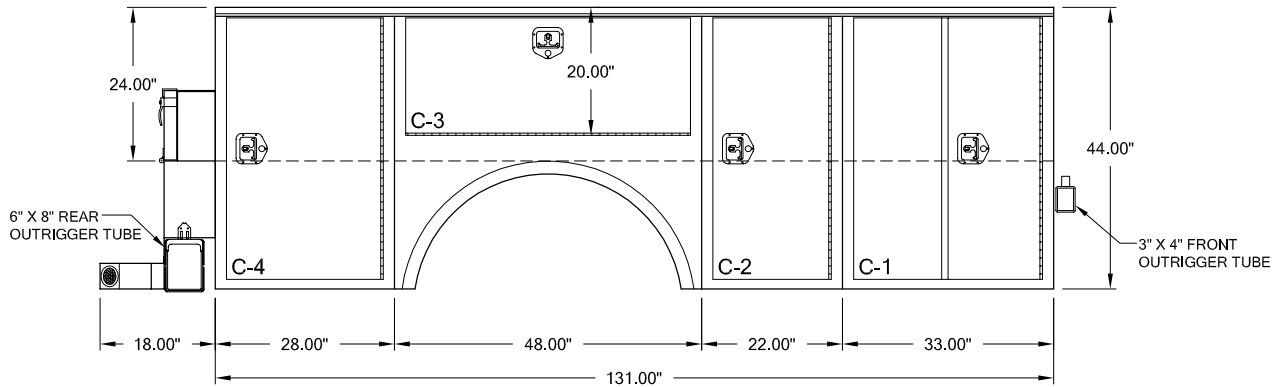

CURB SIDE VIEW

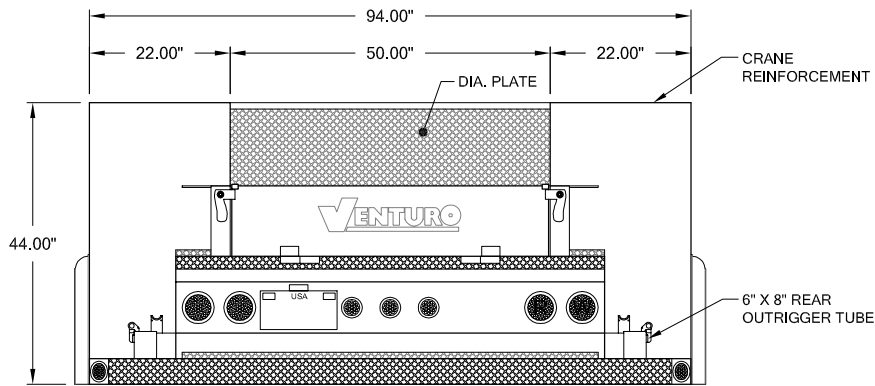

REAR VIEW

NOTES:

- 10 GA. DIAMOND PLATE STEEL BED WALL & COMP'T TOPS
- 12 GA. & 14 GA. JET KOTE GALVANEAL STEEL BODY
- DOUBLE PANEL JET KOTE GALVANEAL STEEL DOORS W/ SPRING DOOR CHECKS
- FLAT 1/8" DIAMOND PLATE DECK WITHOUT WHEEL WELLS
- FULL LENGTH STAINLESS STEEL PIANO HINGE, PIN & T-HANDLE LATCHES W/ LOCKS
- FULL LENGTH DRIP RAIL OVER ALL COMPARTMENT DOORS
- UNOBSTRUCTED CRANE REINFORCED COMPARTMENTS
- TUBULAR LONGITUDINAL FRAME & CRANE COMPARTMENT CROSS MEMBERS
- AUTOMOTIVE TYPE DOOR SEALS & BODY UNDERCOATING

CLEAR DOOR OPENINGS

- S-1/C-1 = 38.00"H X 27.00"W
- S-2/C-2 = 38.00"H X 16.00"W
- S-3/C-3 = 16.00"H X 42.00"W
- S-4/C-4 = 38.00"H X 22.00"W



VENTURO CRANE BODIES

HT 40-131-FLT

SCALE:
N.T.S.

DATE:
09/30/2005

SHEET:
1 OF 1

REV.	DATE

HT 40-131-TFC

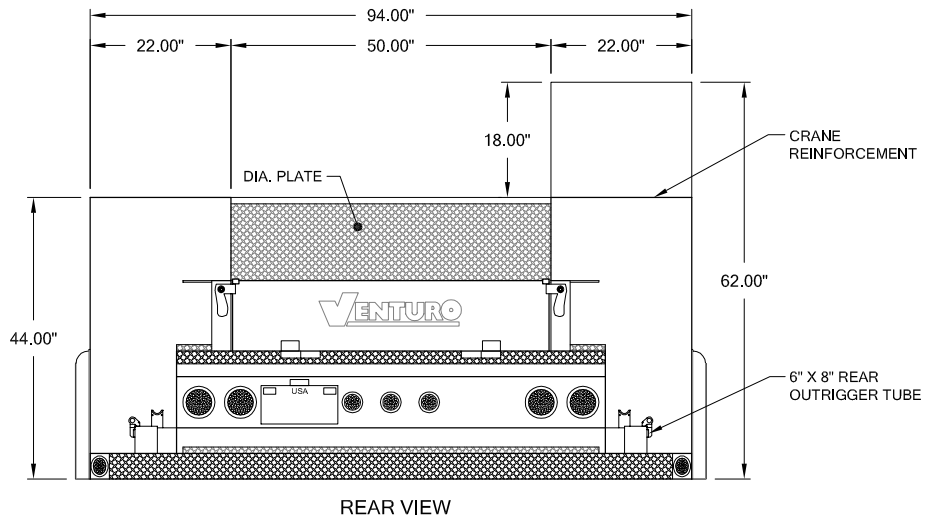
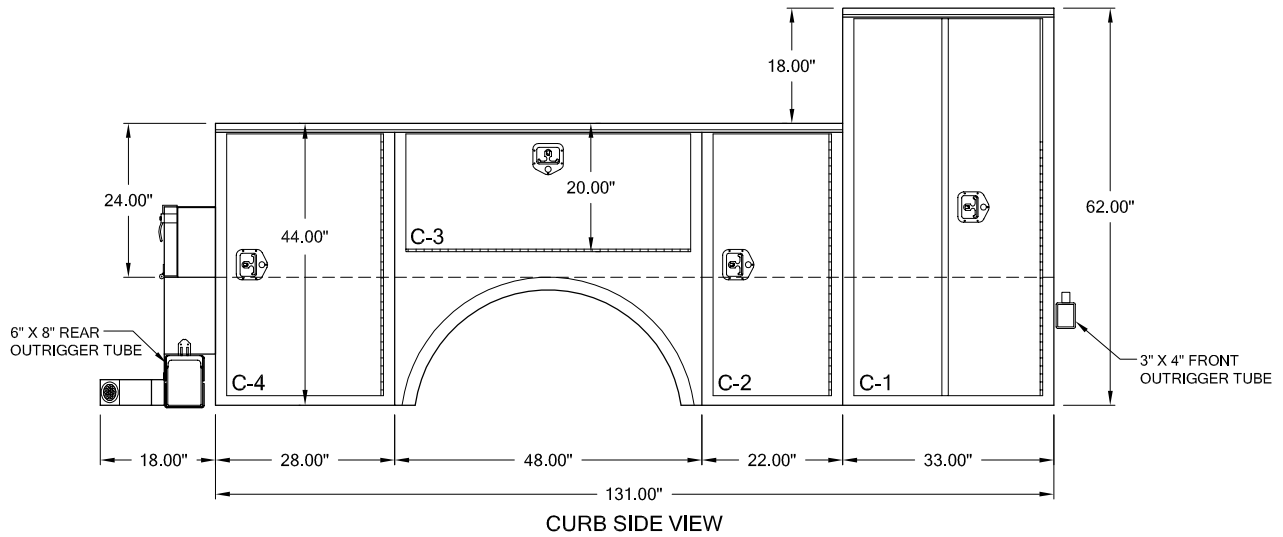
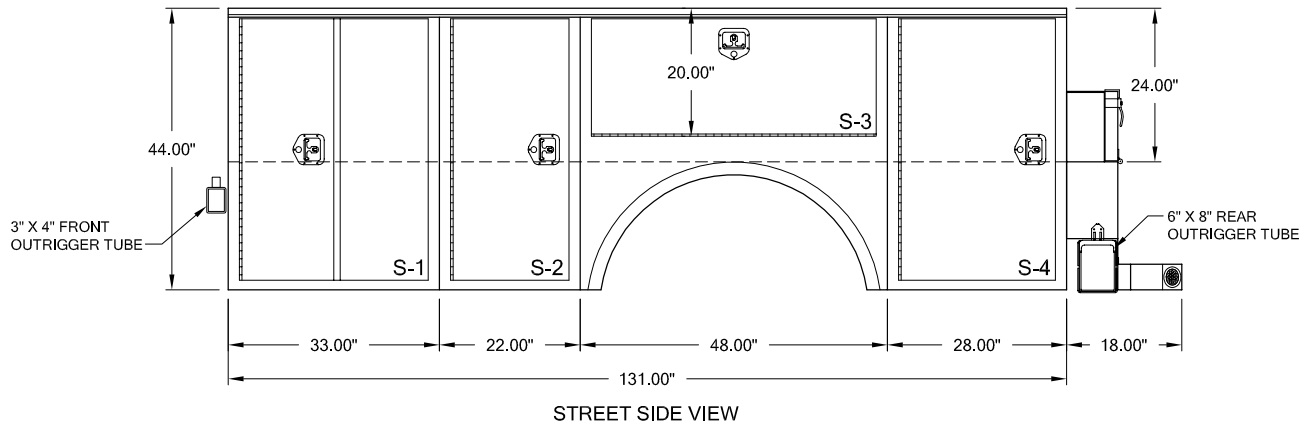

NOTES:

- 10 GA. DIAMOND PLATE STEEL BED WALL & COMP'T TOPS
- 12 GA. & 14 GA. JET KOTE GALVANEAL STEEL BODY
- DOUBLE PANEL JET KOTE GALVANEAL STEEL DOORS W/ SPRING DOOR CHECKS
- FLAT 1/8" DIAMOND PLATE DECK WITHOUT WHEEL WELLS
- FULL LENGTH STAINLESS STEEL PIANO HINGE, PIN & T-HANDLE LATCHES W/ LOCKS
- FULL LENGTH DRIP RAIL OVER ALL COMPARTMENT DOORS
- UNOBSTRUCTED CRANE REINFORCED COMPARTMENTS
- TUBULAR LONGITUDINAL FRAME & CRANE COMPARTMENT CROSS MEMBERS
- AUTOMOTIVE TYPE DOOR SEALS & BODY UNDERCOATING

CLEAR DOOR OPENINGS

S-1 = 38.00"H X 27.00"W	C-1 = 56.00"H X 27.00"W
S-2 = 38.00"H X 16.00"W	C-2 = 38.00"H X 16.00"W
S-3 = 16.00"H X 42.00"W	C-3 = 16.00"H X 42.00"W
S-4 = 38.00"H X 22.00"W	C-4 = 38.00"H X 22.00"W



VENTURO CRANE BODIES

HT 40-131-TFC

SCALE:
N.T.S.

DATE:
09/30/2005

SHEET:
1 OF 1

REV.	DATE

HT 40-131-DTF

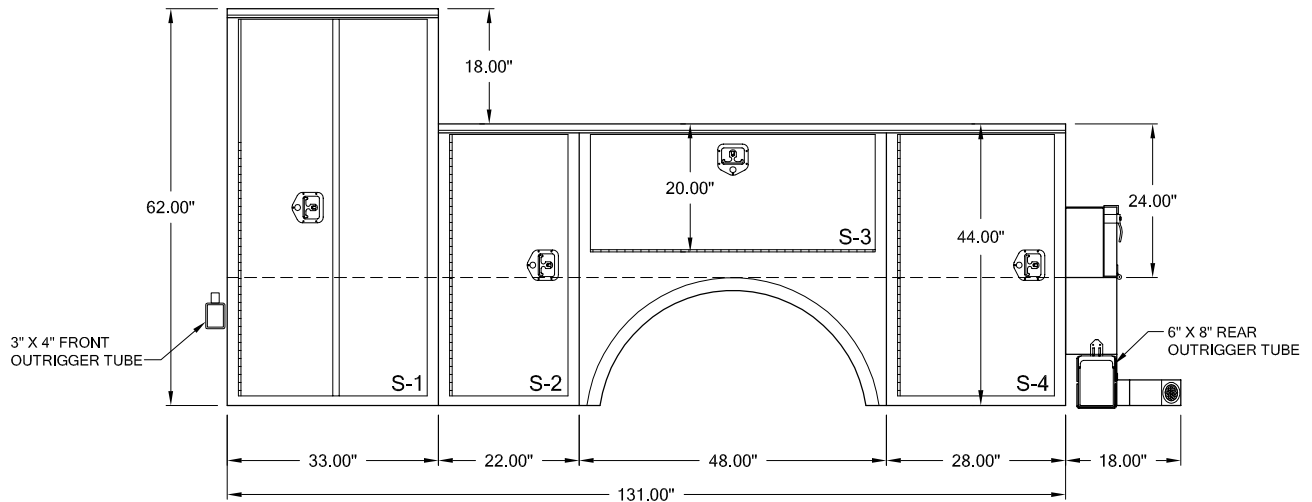

STREET SIDE VIEW

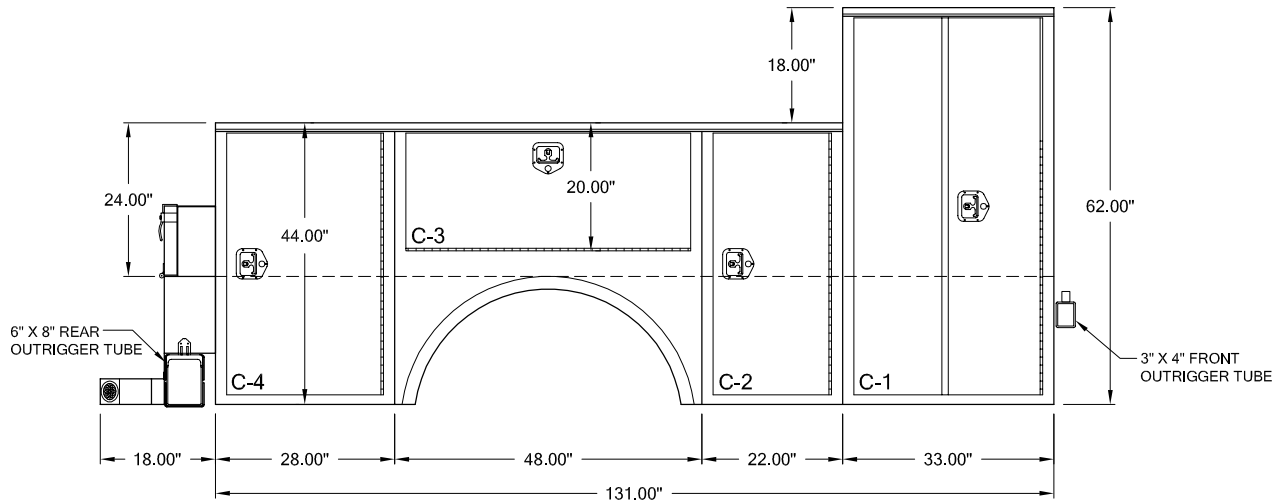

CURB SIDE VIEW

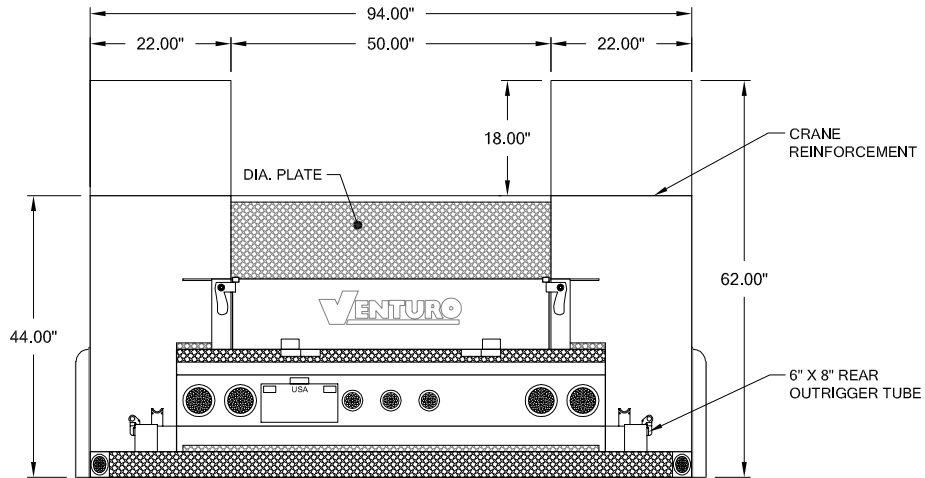

REAR VIEW

NOTES:

- 10 GA. DIAMOND PLATE STEEL BED WALL & COMP'T TOPS
- 12 GA. & 14 GA. JET KOTE GALVANEAL STEEL BODY
- DOUBLE PANEL JET KOTE GALVANEAL STEEL DOORS W/ SPRING DOOR CHECKS
- FLAT 1/8" DIAMOND PLATE DECK WITHOUT WHEEL WELLS
- FULL LENGTH STAINLESS STEEL PIANO HINGE, PIN & T-HANDLE LATCHES W/ LOCKS
- FULL LENGTH DRIP RAIL OVER ALL COMPARTMENT DOORS
- UNOBSTRUCTED CRANE REINFORCED COMPARTMENTS
- TUBULAR LONGITUDINAL FRAME & CRANE COMPARTMENT CROSS MEMBERS
- AUTOMOTIVE TYPE DOOR SEALS & BODY UNDERCOATING

CLEAR DOOR OPENINGS

- S-1/C-1 = 56.00"H X 27.00"W
- S-2/C-2 = 38.00"H X 16.00"W
- S-3/C-3 = 16.00"H X 42.00"W
- S-4/C-4 = 38.00"H X 22.00"W



VENTURO CRANE BODIES

HT 40-131-DTF

SCALE:
N.T.S.

DATE:
09/30/2005

SHEET:
1 OF 1

REV: DATE